

# Low-cost, multispectral light field camera for medical applications

Stefan Kray\*, Florian Blechschmidt\*\*, Moritz Gerlich\*

\*Institute of Smart Systems and Services, Pforzheim University, Germany

\*\*Pforzheim University, Tiefenbronner Str. 65, 75175 Pforzheim, Germany

mailto: stefan.kray@hs-pforzheim.de

We demonstrate a cost-effective multispectral light field camera constructed from standard components. Our system captures images from 5 spectral bands with usable frame rates up to 20 frames per second (fps), resulting in data rates of 100 megapixels per second. We showcase its application in the analysis of tissue oxygenation *in vivo*.

## 1 Introduction

Multispectral imaging captures data in several wavelength regions and is used for tissue discrimination and measurement of oxygen saturation in medical applications [1].

Light field-based approaches are an interesting method for capturing multispectral information [2]. Commercial light field cameras are based on micro-lenses and specialized optics and are cost expensive. To overcome this limitation, we present a custom-built light field camera utilizing standard optical and electronic components and extend it to multispectral imaging.

## 2 System Setup

Our system is built in a modular way, stacking camera modules next to each other. Each camera module is comprised of a camera board and a raspberry pi zero module with a memory card. An optical bandpass filter is added to each camera board to capture the desired wavelength bands.

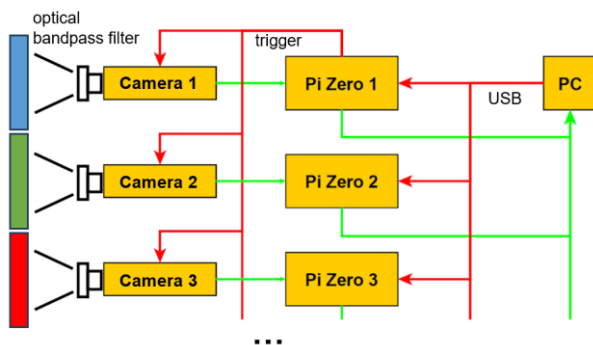

Fig. 1 Optical and electrical setup of the multispectral light field camera.

Fig. 1 illustrates the integration of all camera modules into a single camera. Each camera board is connected to a Raspberry Pi Zero via camera serial interface (CSI). All camera boards are triggered by an electronic hardware signal connected to the first module. This ensures that all images are captured simultaneously. Data is stored on memory

cards after image acquisition and read out via USB-connection to a control PC. The camera currently consists of 5 modules with wavelength regions centered at 460 nm, 550 nm, 630 nm, 730 nm and 850 nm respectively, each with a full width at half maximum (FWHM) bandwidth of  $\Delta\lambda = 20$  nm.

## 3 Data Processing

Light field cameras capture a scene from different perspectives. For multispectral imaging, these perspectives must be fused into a single multispectral data cube.

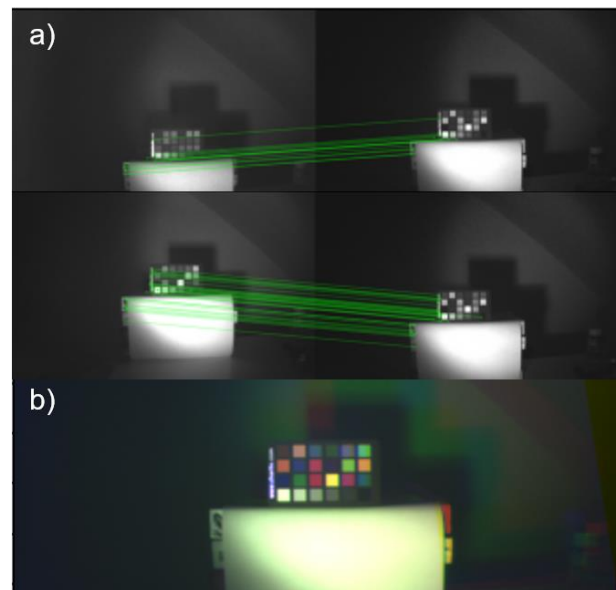

Fig. 2 (a) Calibration based on SIFT features. (b) Multi-spectral image generation by projective transformation.

Fig. 2 (a) illustrates how the data cube is calculated. The features in the calibration image are tracked with the help of a scale-invariant feature transform (SIFT). Homographies are calculated using these features, transforming the images to match the central image of our camera array. In this manner, a multispectral data cube is calculated. Fig. 2(b) shows the RGB subset of this data cube.

Tissue oxygenation is calculated by correlating each pixel of the data cube to reference oxygenation curves [3]. The oxygenation level is calculated by selecting the reference curve which fits best to the spectral signature for each pixel. 2D images are generated where the pixel color is selected according to a color palette, encoding each saturation level to a preselected color value.

#### 4 System Performance

We achieve data rates of 20 fps for time durations of ~ 20 s. Higher frame rates up to 60 Hz are possible; however, the limited writing speed of the memory cards lead to early frame loss.

All images are captured simultaneously, preventing motion artifacts that typically occur when imaging living subjects.

#### 5 Experimental results

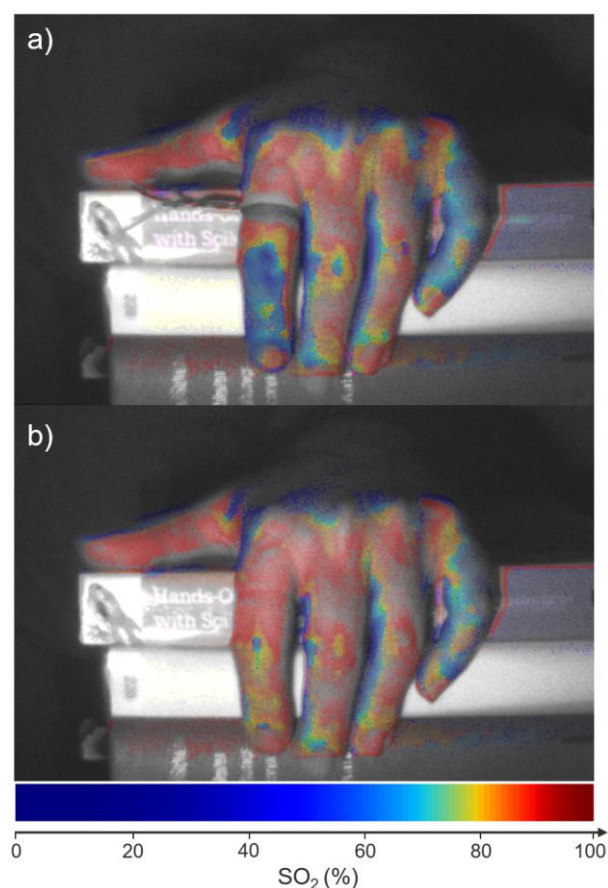

**Fig. 3** Tissue oxygenation visualization. (a) tied-off finger (b) situation ~ 1,5 min after opening the tie. The color scale for coloring each pixel is shown at the bottom of the figure.

Fig.3 shows a human hand with the index finger (a) tied to prevent blood perfusion and (b) after the tie is removed. The visualization clearly shows that the tied finger lacks oxygen. Shortly after the tie is removed, the tissue oxygenation returns to normal levels.

Fig. 4 shows a quantitative analysis of the situation. The oxygenation level of the index finger has been calculated by averaging a region of interest on the index finger for all frames. At the beginning of the measurement, the oxygenation level is about 75-80%, reaching over 90 % after removing the tie.

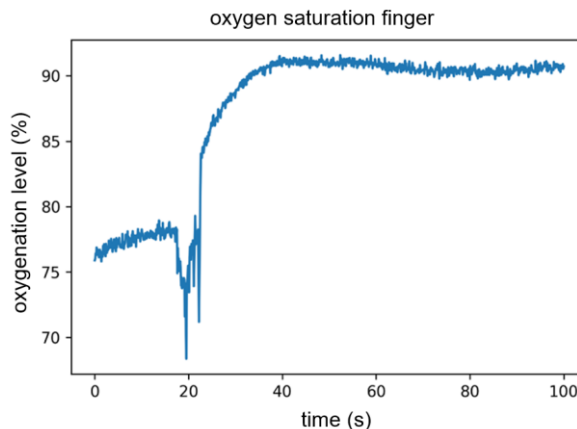

**Fig. 4** Oxygenation level of the index finger over time.

#### 6 Discussion

The camera modules within the camera array have a spacing of ~ 38 mm x 38 mm, resulting in an overall size of 125 mm x 125 mm for 9 camera modules. The large spatial dimensions limit its usability in a clinical context. Furthermore, the performance of the raspberry pi zero module limits the overall frame rate due to frame drops.

#### 7 Conclusion and outlook

We demonstrated a multispectral light field camera made from custom components, costing approximately 70 € per camera module. The camera can be built from off-the shelf components and used for medical applications. A further reduction in spatial dimensions and an increase in computational performance will help to broaden the field of application.

#### 8 Acknowledgement

This work was created as part of the 'Neospek' project (P2022-07-006). The project was made possible by funding from the Carl-Zeiss-Stiftung.

#### References

- [1] J. Shapey et. al, „Intraoperative multispectral and hyperspectral label-free imaging” in: *Journal of Biophotonics* **12**(9), e201800455 (2019).
- [2] E. L. Wisotzky, “3D Hyperspectral Light-Field Imaging: a first intraoperative implementation”, *Current Directions in Biomed. Eng.* **9**(1):611-614, (2023)
- [3] Chang et.al., „Whole blood reflectance for assessment of hematologic condition and detection of angiographic contrast media“; *Applied Optics* Vol. **48** (No 13), 2435 ff (2009)